

GLOBE VALVE FLANGED END JIS 10K

Model : ARV-102FE(J)

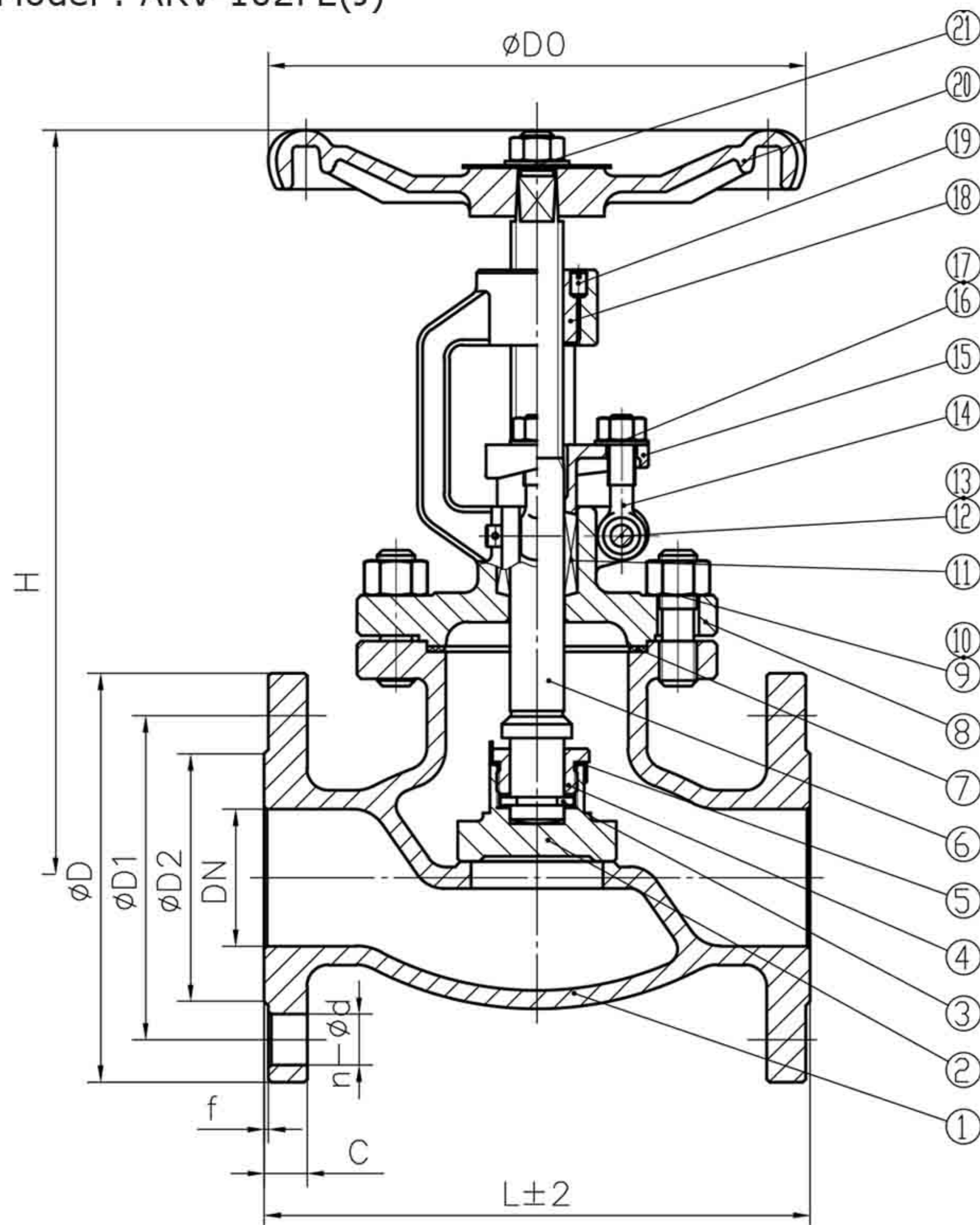

Nominal pressure	10K	
Test Pressure	Shell Test	3.0 Mpa
	Seal Test	2.2 Mpa
Applicable Medium	Water, Oil, Gas	
Applicable Temperature	-29 ~ 425 °C	

Dimension in mm

SIZE		L	D	D1	D2	C	f	n- ϕd	W	H
DN	in.									
15	1/2"	108	90	60.3	34.9	10	1.6	4- $\phi 16$	120	185
20	3/4"	117	100	69.9	42.9	11	1.6	4- $\phi 16$	120	193
25	1"	127	110	79.4	50.8	12	1.6	4- $\phi 16$	140	208
32	1.1/4"	140	115	88.9	63.5	13	1.6	4- $\phi 16$	160	222
40	1.1/2"	165	125	98.4	73	15	1.6	4- $\phi 16$	180	252
50	2"	203	150	120.7	92.1	16	1.6	4- $\phi 19$	200	278
65	2.1/2"	216	180	139.7	104.8	18	1.6	4- $\phi 19$	240	321
80	3"	241	190	152.4	127	19	1.6	4- $\phi 19$	280	355
100	4"	292	230	190.5	157.2	24	1.6	8- $\phi 19$	300	412
125	5"	356	255	215.9	185.7	24	1.6	8- $\phi 22$	320	455
150	6"	406	280	241.3	215.9	26	1.6	8- $\phi 22$	360	510
200	8"	495	345	298.5	270	29	2	8- $\phi 22$	-	-
250	10"	622	405	362	324	30.6	2	12- $\phi 25$	-	-
300	12"	698	485	431.8	381	32.2	2	12- $\phi 25$	-	-
350	14"	787	535	476.3	413	35.4	2	12- $\phi 29$	-	-

Features :

Face to Face : JIS B2002

End Flange dimension according to JIS B2212

Material

No	PART	MATERIAL	
1	BODY	A351 CF8	A351 CF8M
2	DISC	A351 CF8	A351 CF8M
3	SPLIT COLLAR	SS304	SS316
4	DISC CAP	SS304	SS316
5	LOCK WASHER	SS304	SS316
6	STEM	A276 304	A276 316
7	GASKET	SPIRAL WOUND GASKET	
8	BONNET	A351 CF8	
9	BOLT	A193 B8	A193 B8M
10	NUT	A194 8	A194 8M
11	PACKING	FLEXIBLE GRAPHITE	
12	SPLIT COTTERS	SS304	
13	PIN	SS304	
14	EYE BOLT	A193 B8	A193 B8M
15	GLAND	A351 CF8	
16	WASHER	SS304	
17	NUT	A194 8	A194 8M
18	STEM NUT	ZCuAl10Fe3	
19	SCREW	A193 B8	A193 B8M
20	HANDWHEEL	IRON AND STEEL	
21	NAME PLATE	STEEL	

The contents of this literature are for informative purposes only. Arita is not responsible for suitability or compatibility of these products in relation to system requirement. For specific requirements, consult Arita or its distributors. Arita reserves the right to change or modify product design without prior notice.