



UNIMECH GROUP, MALAYSIA



A MEMBER OF UNIMECH GROUP, MALAYSIA

KNIFE GATE VALVE FLANGED END JIS 10K

ARV-810FE(J)

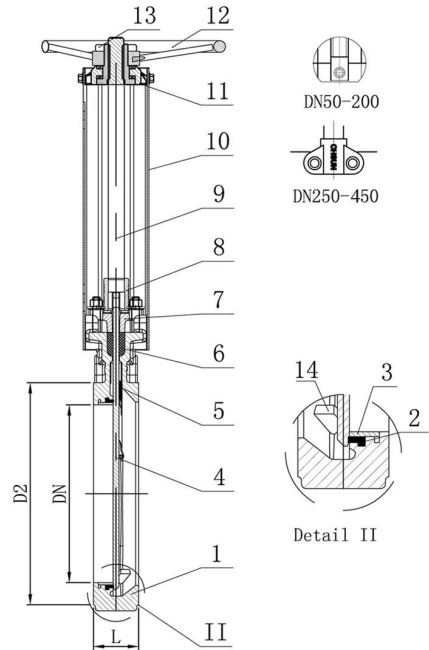
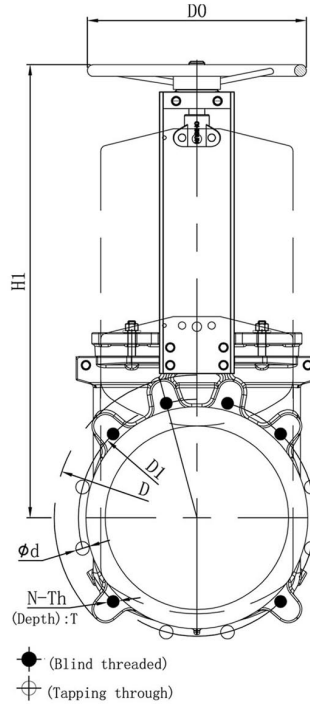

Features :

Working Pressure : 10 bar / 150 psi
 Working Temperature : -10 to 120°C
 Flange Connection : JIS 10K

Material

No	PART	MATERIAL
1	BODY	CAST IRON
2	SEAT	EPDM
3	STEEL RING	SS304
4	DISC	SS304
5	GUIDE PAD	PTFE
6	PACKING	PTFE
7	PACKING GLAND	WCB

Technical Data

No	PART	MATERIAL
8	CHUCK	WCB
9	STEM	2Cr13 (SS420)
10	YOKE	Q235(Cr.D)
11	YOKE HEAD	Assembly
12	HANDWHEEL	CAST IRON
13	CAP	Q235 (Cr.D)
14	WEDGE	GGG40

Dimension in mm

DN	L	D	D1	D2	D0	N-Th	T	●	⊕	d	H1
50	48	155	120	96	180	4-M16	12	2	2	Ø19	292
65	48	175	140	116	200	4-M16	12	2	2	Ø19	320
80	51	185	150	126	200	8-M16	12	2	6	Ø19	348
100	51	210	175	151	240	8-M16	12	2	6	Ø19	395
125	57	250	210	182	260	8-M20	14	2	6	Ø23	450
150	57	280	240	212	280	8-M20	14	2	6	Ø23	504
200	70	330	290	262	300	12-M20	18	4	8	Ø23	617
250	70	400	355	324	320	12-M22	18	4	8	Ø25	758
300	76	445	400	368	350	16-M22	20	10	6	Ø25	857
350	76	490	445	413	400	16-M22	20	10	6	Ø25	946
400	89	560	510	475	450	16-M24	24	10	6	Ø27	1023
450	89	620	565	530	500	20-M24	24	14	6	Ø27	1091

The contents of this literature are for informative purposes only. Arita is not responsible for suitability or compatibility of these products in relation to system requirement. For specific requirements, consult Arita or its distributors. Arita reserves the right to change or modify product design without prior notice.