

ELECTRIC ACTUATOR



"UIC" series electric actuator is used for controlling 90° rotation of the valves and other similar products, such as Butterfly Valve, Ball Valve, Damper, Cock Valve and etc. It is widely applies to water treatment, paper mill, Air Ventilation, Filtration System, light industry and etc.

Model	Max Torque (N.M)	Operating Time 90° (s)	Motor (W)	Rated Current (single phase 230Vac 50Hz)	Weight (Kg)
UIC-005	50	26	10	0.25	3.6

Specification

Shell	Aluminium alloy Shell, Enclosure IP68, NEMA4 and 6
Power	Standard: 230Vac Single phase (± 10%), Option : 110Vac Single Phase, 24Vdc
Motor	Squirrel-cage Asynchronous Motor
Limit Switch	2 X Open/Close, SPDT, 250Vac 10A
Auxiliary Limit Switch	2 X Open/Close, SPDT, 250Vac 10A
Stroke	90° ± 10°
Stall Protection	Internal-placed thermal protection
Indicator	Continuous situation indication
Manual operation	Mechanical handle with alley key
Self-locking device	Self-locking by worm gear
Mechanical Limit	2 external adjustable screws
Space Heater	7 ~ 10 W (220Vac) Anti-condensation
Conduit entries	2 X M18
Ambient temperature	-20° C ~ +70° C
Lubrication	Grease Molybdenum (EP type)
Material	Steel, Aluminium alloy, Aluminium bronze, Polycarbonate
Ambient humidity	max 90% RH
Anti-vibration	X Y Z 10g, 0.2~34 Hz, 30 minutes
External coating	Dry powder, Epoxy polyester

Appearance View and Dimension

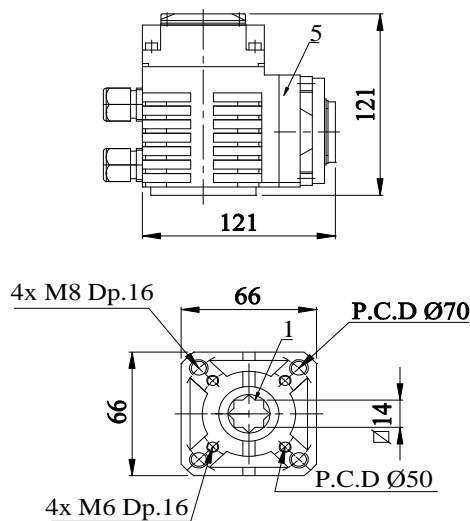
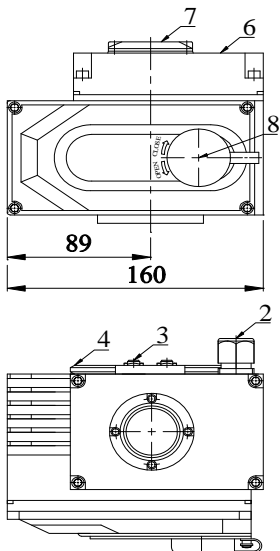

- 1 Output axis
- 2 Cable Gland
- 3 Mechanical limit
- 4 Alley key
- 5 Actuator Shell
- 6 Wiring Cover
- 7 Sight glass
- 8 Anti-dust cover

Circuitry

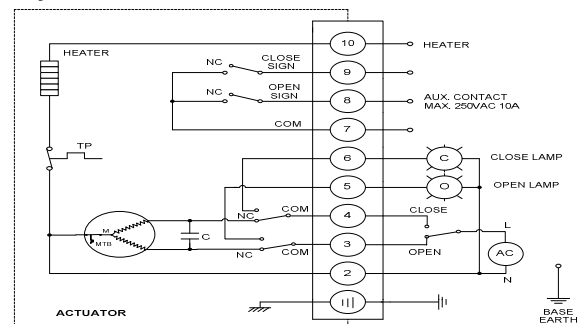

*All dimension in unit mm

*all technical specification are without obligation.