

ELECTRIC ACTUATOR

Quarter-turn (QT Model)



UNIMECH INSTRUMENTS & CONTROL SDN. BHD

50, LENGKOK KAPAL, TAMAN INDUSTRI CHAIN FERRY, 12100 BUTTERWORTH, PENANG.

CONSTRUCTION

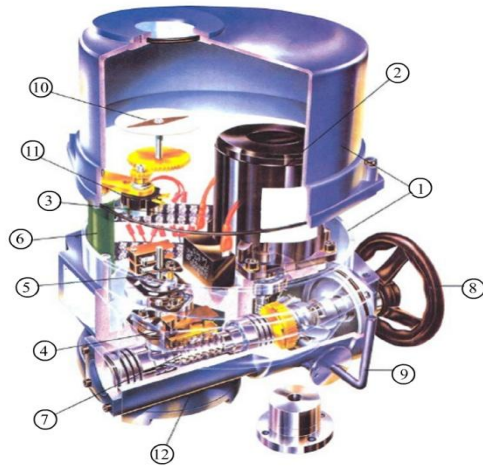

FEATURES

1. ENCLOSURE

Standard enclosure fulfilled protection class IP 67, NEMA 4 & 6. (Explosion proof version is available.)

2. MOTOR

Squirrel cage motor is of encapsulated type, with high stall torque and low inherent force for seating & unseating of valves. All motor are integrated with build-in thermal protection.

3. TERMINAL CONNECTION & WIRING

Terminal connection is of "WAGO" push on type, making wiring connection very easy & without fuss. Electric wiring circuit is standardized for single & three phase voltage. Additional terminal is available on request.

4. LIMIT SWITCHES

A pair of limit switches are activated by means of simple, reliable & adjustable cam plates, mounted directly onto, and driven by center column. The unique cam plate design does not allow over travel of limit switches.

5. TORQUE SWITCHES

Electric actuators with torque more than 100 Nm, are installed with torque switches for over-load protection

6. HEATER

For prevention of condensation due to weather & temperature changes, and also keeps internal components clean & dry. A 20 watt space heater is provided inside all the electric actuator.

7. SELF LOCKING MECHANISM

Because of the worm gear design system, all the electric actuators are self locking.

8. HANDWHEEL

Correct size of hand - wheel on the electric actuator ensure adequate strength for safe and efficient emergency operation.

9. MANUAL OVER-RIDE

Engage by pulling the lever & turning the hand-wheel. Lever is auto declutch when power supply is switched on, and hand-wheel does not turn as extra safety feature.

10. VISUAL POSITION INDICATOR

The visual position indicator is directly mounted onto the center drive column to provide the visual position of the valve.

11. POTENTIOMETER – (OPTIONAL)

Is available on request, is to provide & transmit remote indication of valve position.

12. MOUNTING & ADAPTOR

Bottom flange mounting dimension conform to ISO 5211. A adaptor drive bushing is provided for every electric actuator, is removable and for machining to suite valve stem size.

Quarter-turn Electric Actuators (QT Model)



PERFORMANCE

Type	Model	Max Output Torque	Operating Time 60/50Hz	Max Stem Dia.	Motor Class	230Vac Single-Phase Current of Motor (A)		Capacitor uF/450V	Number of handle Turn 90Deg	Weight (Kgs)
		N-m	30 Deg.	mm	F	Rated	Locked rotor			
QT1*	QT-03	30	11/13	14	8	0.3	0.48	2.5	7	8
	QT-04	40	11/13	14	10	0.3	0.48	2.5	7	8
	QT-06	60	13/16	22	15	0.58	0.67	4	8.5	11
	QT-09	90	13/16	22	25	0.65	0.75	4	8.5	12
QT2	QT-15	150	17/20	22	40	0.95	1.05	7	12.5	15
	QT-19	190	17/20	22	40	0.95	1.05	7	12.5	15
QT3	QT-28	280	20/24	32	40	0.95	1.5	7	10	19
	QT-38	380	20/24	32	60	1.4	1.75	10	10	20
	QT-50	500	20/24	32	90	1.8	1.9	12	10	21
QT4	QT-60	600	24/29	42	90	1.8	3	12	14.5	24
	QT-80	800	24/29	42	180	2.2	3.5	20	14.5	25
	QT-100	1000	24/29	42	200	2.4	3.8	20	14.5	28

STANDARD SPECIFICATION

Housing & Cover	Aluminium Alloy, Anodized	Travel Angle	90° ± 5°
Enclosure	Watertight IP67, Nema 4 and 6	Indicator	Continuous Position Indicator
Ambient Temp	~30° to 70°C, 150 C/1hr	Manual Override	HAND/AUTO Decoupling Mechanism
Power Supply (60Hz/50Hz)	230VAC, 1Phase Option - 110VAC, 1Phase 220/380/440VAC, 3 Phase	Self Locking	Provide by means of Worm Gearing
		End Stopper	External Adjustable Screws
Control Power	230VAC, 1Phase, 60/50Hz	Space Heater	20W for Anti-Condensation
Torque Switches	2 x SPDT for QT 15 and above	Conduit Entries	Two PF3/4"
Limit Switches	2 X SPDT 15 A.	Lubrication	Grease NLGI Grade 2 (EP Type)
Stall Protection	Built-in Thermal Protection OPEN 120°C ± 5°/Close 77°C ± 15°C	Materials	Steel, Aluminium Alloy, Al Bronze
		External Coating	Dry Powder, Epoxy-Polyester Munsell No.FJ-002

DIMENSION

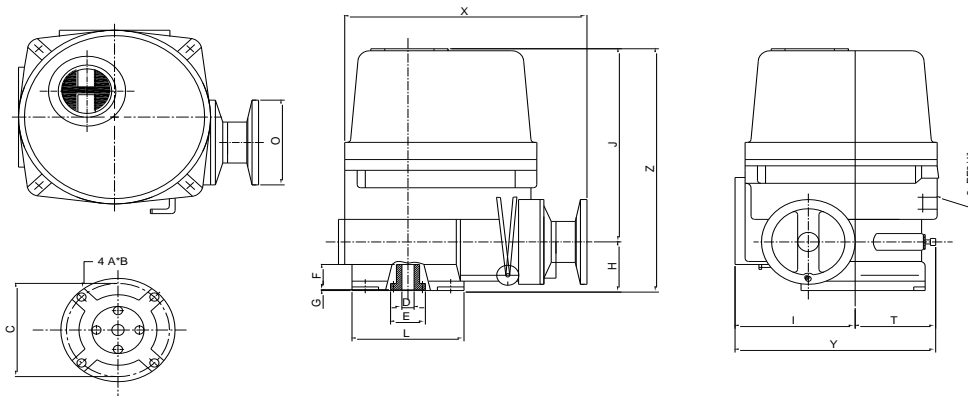

Type	QT3	QT4	QT6	QT9	QT15	QT19	QT28	QT38	QT50	QT60	QT80	QT100
ISO 5211	F05/ F07	F05/ F07	F05/ F07	F05/ F07	F07	F07	F10/ F12	F10/ F12	F10/ F12	F10/ F14	F10/ F14	F10/ F14
C	50	50	50/ 70	70	70	70	102/ 125	102/ 125	102/ 125	102/ 140	102/ 140	102/ 140
A	M6	M6	M6/ M8	M8	M8	M8	M10/ M12	M10/ M12	M10/ M12	M10/ M16	M10/ M16	M10/ M16
B	14	14	14/16	16	14	14	17/19	17/19	17/19	15/24	15/24	15/24
D (Max)	14	14	14	22	22	22	32	32	32	42	42	42
E	40	40	40	54	57	57	75	75	75	85	85	85
F	25	25	25	35	35	35	42	42	42	50	50	50
G	5	5	5	5	5	5	1.5	1.5	1.5	1.5	1.5	1.5
H	60	60	60	60	65	65	70	70	70	78	78	78
I	125	125	125	125	150	150	180	180	180	191	191	191
J	196	196	196	196	198	198	231	231	231	265	265	265
L	102	102	102	102	125	125	145	145	145	175	175	175
O	200	200	200	200	200	200	250	250	250	250	250	250
T	75	75	75	75	90	90	100	100	100	116	116	116
X	240	240	240	240	260	260	285	285	285	325	325	325
Y	200	200	200	200	240	240	280	280	280	307	307	307
Z	256	256	256	256	263	263	301	301	301	343	343	343

Quarter-turn Electric Actuators (QT Model)



CIRCUIT DIAGRAM (WIRING)

QT3 ~ QT9

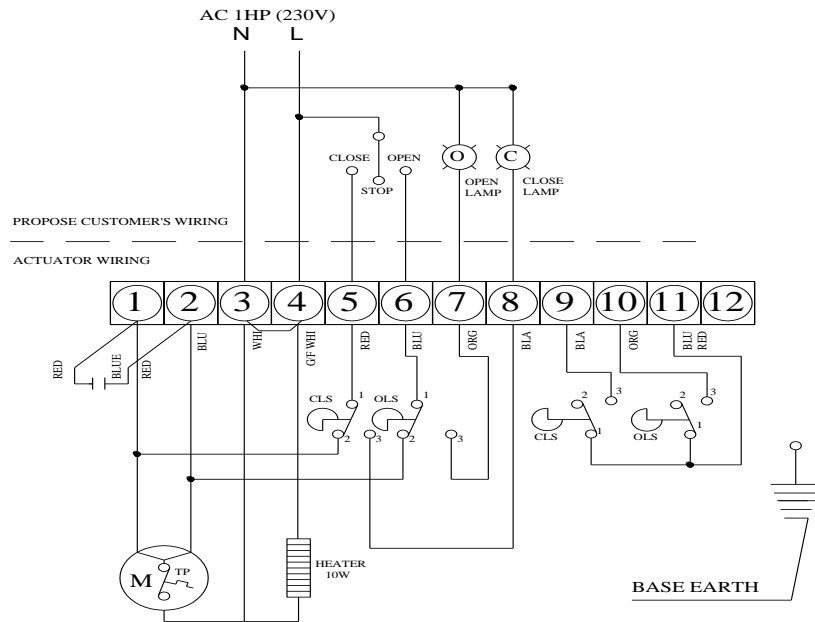

QT15 ~ QT100

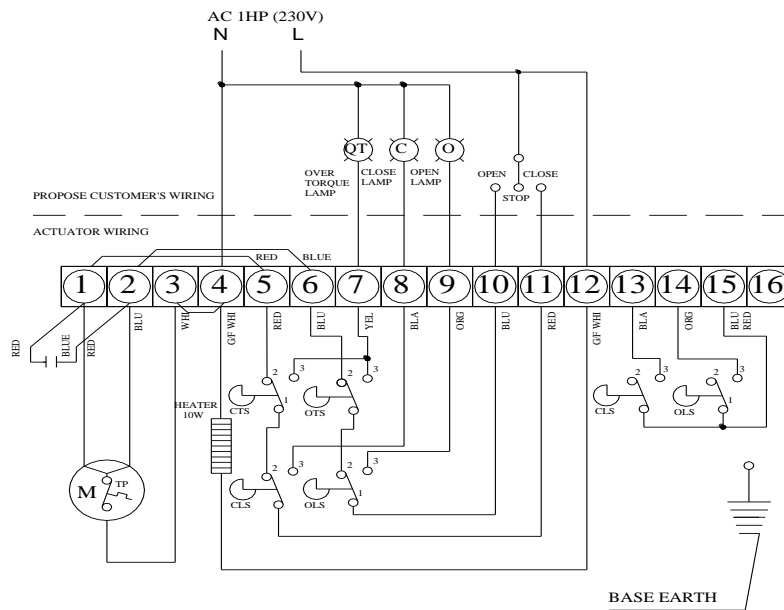

Any enquires, please contact :
 Unimech Instruments & Control Sdn Bhd.
 50, Lengkok Kapal, Taman Industry Chain Ferry,
 12100 Butterworth, Penang, Malaysia.
 Tel : 604-3248788, 3330393
 Fax : 604-3249788
 Email : UIC_Sdn Bhd@yahoo.com