



UNIMECH GROUP, MALAYSIA



A MEMBER OF UNIMECH GROUP, MALAYSIA

CAST IRON STEAM TRAP CLASS 16K SCREWED END

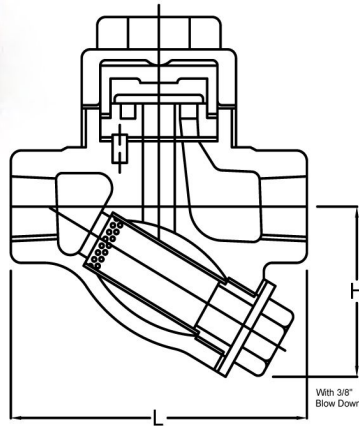

- Please name the model No. (ST-8LS) when negotiation.
- Thread: BS21, ANSI B2.1 or DIN-259.
- Working Temperature: 120°C
- Max. Temperature: 220°C

- Test Pressure: Body 32 kgf/cm² (Hydrostatic)
- Working Pressure: 0.3 kgf/cm² - 16 kgf/cm²

Material

Model	ST-8LS
Body	IRON
Bonnet/Plug	IRON
Seat	SS 410
Disc	SS 304
Seal	PTFE
Packing	PTFE
Screen	SS 304

Dimension

Size	inch	1/2	3/4	1
	mm	15	20	25
L		95	105	110
H		56	65	70

Capacity

P kg/cm ²	kgf/H															
	0.3	0.6	1	2	3	4	5	6	8	10	12	14	16			
15	160	205	250	320	380	420	460	490	540	590	630	660	690			
20	230	295	360	460	530	590	640	690	770	840	900	960	1000			
25	290	380	460	590	680	760	820	880	980	1060	1130	1200	1260			

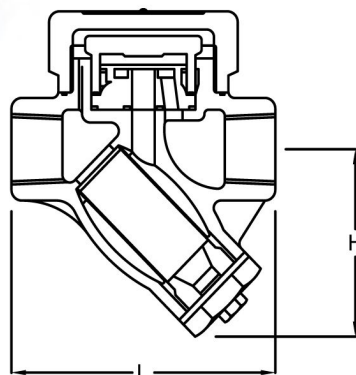

BONNET:

1/2", 3/4", 1" OCTAGON
1 1/4", 1 1/2", 2" TETRAGON

- Please name the model No. (ST-T3A) when negotiation.
- Thread: BS21, ANSI B2.1 or DIN-259.
- Working Temperature: 120°C
- Max. Temperature: 220°C

- Test Pressure: Body 32 kgf/cm² (Hydrostatic)
- Working Pressure: 0.3 kgf/cm² - 16 kgf/cm²

Material

Model	ST-T3A
Body	IRON
Bonnet/Plug	IRON
Seat	SS 410
Disc	SS 304
Seal	PTFE
Packing	PTFE
Screen	SS 304

Dimension

Size	inch	1/2	3/4	1	1.1/4	1.1/2	2
	mm	15	20	25	32	40	50
L		97	105	112	184	187	201
H		67	75	90	105	110	130

Capacity

P kg/cm ²	kgf/H															
	0.3	0.6	1	2	3	4	5	6	8	10	12	14	16			
15 - 25	183	220	253	300	345	385	420	450	510	570	630	690	740			
32	350	410	490	620	730	820	900	960	1080	1200	1320	1440	1560			
40	440	520	610	780	900	1000	1090	1180	1350	1500	1650	1790	1930			
50	460	560	670	850	1000	1110	1220	1320	1500	1680	1860	2030	2200			