



UNIMECH GROUP, MALAYSIA



A MEMBER OF UNIMECH GROUP, MALAYSIA

STAINLESS STEEL NEEDLE VALVE SCREWED END

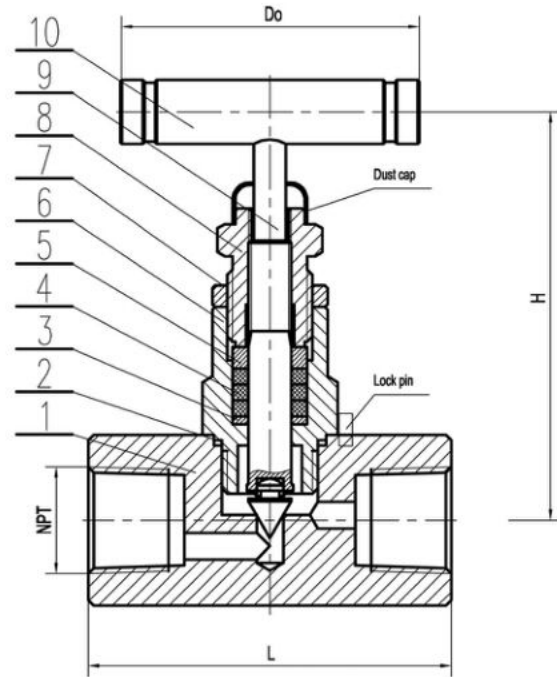

Dimension in mm

SIZES		L	H	Do	WT. (KG)
DN	in.				
6	1/4	57	78	57	0.35
10	3/8	57	78	57	0.35
15	1/2	68	92	63	0.5
20	3/4	80	119	80	1
25	1	90	100	90	1.5

Technical Data

Material

No.	PART	MATERIAL
1	BODY	SS 316
2	SUPPORTS	SS 316
3	PACKING SEAT	SS 316
4	PACKING	PTFE
5	PRESSURE RING	SS 316
6	BONNET	SS 316
7	PANEL NUT	SS 316
8	PACKING BOLT	SS 316
9	STEM	SS 316
10	DISC	SS 316
11	HANDLE	SS 304

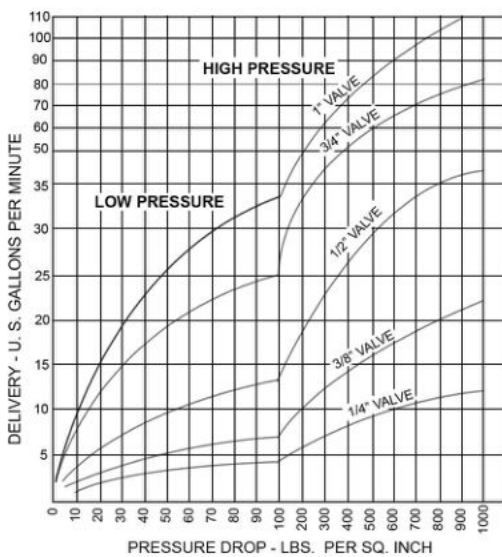

Features

- * T-bar Handle
- * Teflon Packing
- * Roll-formed Stem Thread
- * Test Pressure Shell 10,000PSI Seat 6600PSI
- * Pressure Rating 6000PSI 42MPA/PN420 WOG
- * Back Seat Design For Re-pack under pressure
- * Screwed End To BSP. BSPT, NPT, DIN259 Spec.
- * Adjustable Gland Ring
- * Metal-to-metal Seat