

# ARITA STAINLESS STEEL BALL VALVE

## FULL PORT 3-PC BODY BALL VALVE 1000 W.O.G.

ARV-100BW-3PC

### SPECIFICATIONS

- Butt weld end
- Design Standard : ASME B16.34
- Blow out proof design
- Inspection and Test : API 598
- Applicable Media : W.O.G.
- Applicable Temperature : -29 ~ 180 °C

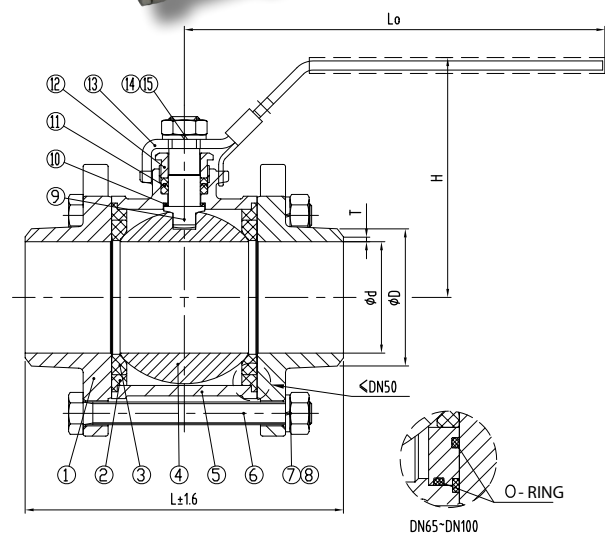

### DIMENSION TABLE (MM)

Size		L	d	D	T	L0	H	Weight (Kg)
DN	Inch							
8	1/4	65	11	14.3	1.6	95	48.5	0.39
10	3/8	65	11.5	17.6	1.6	95	48.5	0.37
15	1/2	75	15	21.8	1.6	105	54	0.51
20	3/4	80	19.5	27.2	1.6	120	65.5	0.65
25	1	90	25	33.9	1.6	140	72	0.87
32	1-1/4	110	32	42.7	1.6	150	81	1.60
40	1-1/2	120	38	48.8	1.6	170	96	1.94
50	2	140	49	61.2	1.6	185	105	2.97
65	2-1/2	160	64	73.9	1.6	220	120	5.55
80	3	180	77	89.8	1.6	270	134.5	7.59
100	4	215	99	115.2	1.6	330	167	12.45

### STANDARD COMPONENT MATERIAL

NO	DESCRIPTION	QTY.	MATERIAL
1	Bonnet	2	SS 304 / SS 316
2	Gasket	2	RPTFE
3	Seat	2	RPTFE
4	Ball	1	SS 304 / SS 316
5	Body	1	SS 304 / SS 316
6	Hex Bolt	4	Stainless Steel
7	Spring Washer	4	Stainless Steel
8	Nut	4	Stainless Steel
9	Stem	1	SS 304 / SS 316
10	Stem Washer	1	RPTFE
11	Packing	1	RPTFE
12	Gland	1	Stainless Steel
13	Handle	1	Stainless Steel
14	Spring Washer	1	Stainless Steel
15	Nut	1	Stainless Steel

### TEST PRESSURE

Nominal Pressure	:	1000 Psi (6.9 MPa)
Hydrostatic Shell Test Pressure	:	1500 Psi (10.4 MPa)
Hydrostatic Seat Test Pressure	:	1100 Psi (7.6 MPa)
Gas Seat Test Pressure	:	90 Psi (0.6 MPa)