

# ARITA STAINLESS STEEL GATE VALVE

## CLASS 200 / 600 GATE VALVE (BSPT)

ARV-101SE

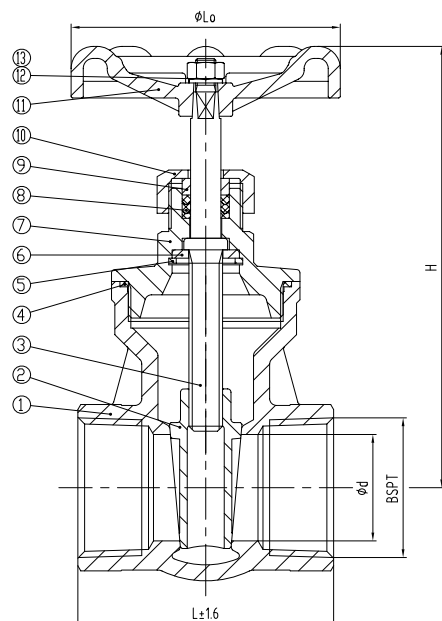

### STANDARD COMPONENT MATERIAL

NO	DESCRIPTION	QTY.	MATERIAL
1	Body	1	Stainless Steel
2	Disc	1	Stainless Steel
3	Stem	1	Stainless Steel
4	Gasket	1	RPTFE
5	Ring	1	Stainless Steel
6	Washer	1	Stainless Steel
7	Bonnet	1	Stainless Steel
8	Packing	1	RPTFE
9	Gland	1	Stainless Steel
10	Packing Nut	1	Stainless Steel
11	Handwheel	1	Aluminium
12	Spring Washer	1	Steel
13	Nut	1	Steel

### SPECIFICATIONS

- Stainless steel body and bonnet
- Screwed end (BSPT)
- Applicable temperature : -20 ~ 180 ° C
- Applicable media : W.O.G. and steam

### TEST PRESSURE

Nominal Pressure	:	200 Psi (1.4 MPa)
Shell Test Pressure	:	300 Psi (2.1 MPa)
Seat Test Pressure	:	220 Psi (1.5 MPa)
Gas Seat Test Pressure	:	90 Psi (0.6 MPa)

### DIMENSION TABLE (MM)

DN	L	d	BSPT	Lo	H	Weight (Kg)
15	55	14	1/2	70	92	0.36
20	60	20	3/4	70	101	0.49
25	68	25	1	80	113	0.68
32	76	32	1-1/4	80	133	0.99
40	80	40	1-1/2	100	153	1.46
50	93	50	2	100	171	2.17
65	113	63	2-1/2	140	205	5.35
80	137	72	3	140	226	7.10