

ARFS/NTGA-XXX  
ARFS/SWGA-XXX

ARFSNTGA-XXX  
ARFSSWGA-XXX



UNIMECH GROUP, MALAYSIA

A MEMBER OF UNIMECH GROUP, MALAYSIA

## FORGED STAINLESS STEEL GATE VALVE CLASS 800

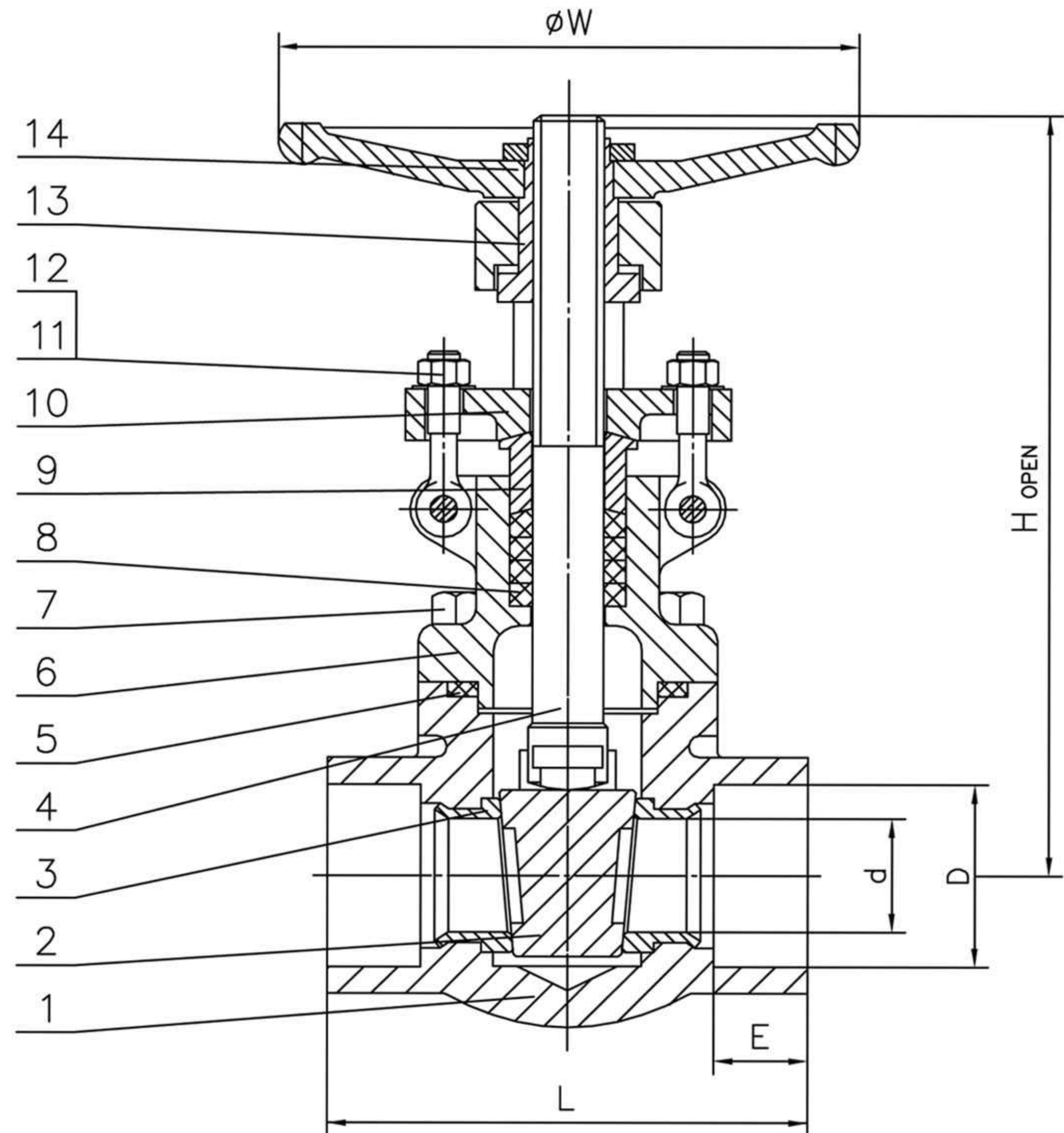

### Technical Data

#### Features :

- \* Class 800
- \* Pressure Temperature Rating : ASME B 16.34
- \* Inspection & Test : API 598
- \* End Connection : i) Socket Weld ( ANSI B16.11)  
ii) NPT (ANSI B1.20.1)
- \* Applicable : Water, Oil & Gas

#### Material

No.	PART	MATERIAL
1	BODY	ASTM A182 F304/316
2	WEDGE	ASTM A182 F304/316
3	SEAT RING	ASTM A182 F304/316
4	STEM	ASTM A182 F304/316
5	GASKET	GRAPHITE+SS304/316
6	BONNET	ASTM A182 F304/316
7	BONNET BLOT	ASTM A193 B8
8	STEM PACKING	GRAPHITE
9	GLAND	ASTM A182 F304/316
10	GLAND FLANGE	ASTM A182 F304/316
11	GLAND EYEBOLT	ASTM A193 B8
12	GLAND NUT	ASTM A194 8
13	STEM NUT	ASTM A276 410
14	HAND WHEEL	ASTM A197

#### Dimension in mm

SIZES		d	D	E	L	H	W
DN	in.						
15	1/2"	10.5	21.8	9.6	79	140	98
20	3/4"	13.5	27.2	12.7	92	143	98
25	1"	18	33.9	12.7	111	170	125
40	1.1/2"	29	48.8	12.7	120	210	160
50	2"	36	61.2	16	140	245	185