



UNIMECH GROUP, MALAYSIA



A MEMBER OF UNIMECH GROUP, MALAYSIA

## CAST STEEL S-PATTERN GLOBE VALVE FLANGED END PN40

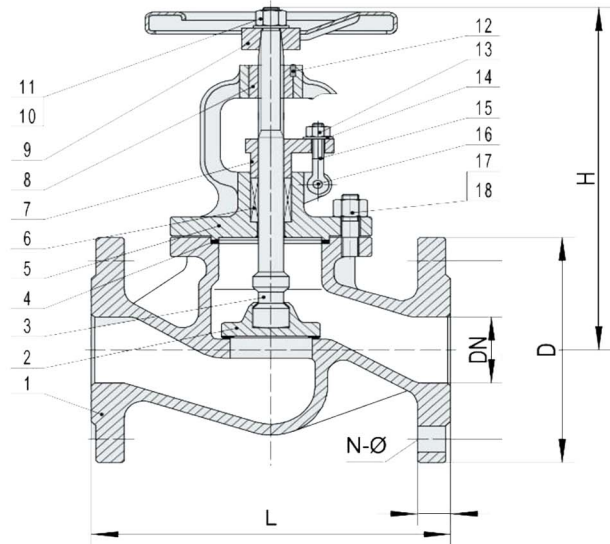

### Features :

- Face to Face is according to DIN 3202
- Flange drilled is according to PN 40
- Working Pressure : PN 40
- Test Pressure Shell : 6.0 Mpa
- Sealing Test (water) : 4.0 Mpa
- Service Temperature : 23 bar up to 400 deg C  
27 bar up to 300 deg C  
40 bar up to 120 deg C

### Technical Data

#### Material

No.	PART	MATERIAL
1	BODY	GS-C25+13Cr
2	DISC	CS+13Cr
3	STEM	13Cr
4	GASKET	SS304+GRAPHITE
5	COVER	GS-C25
6	GLAND PACKING	GRAPHITE
7	GLAND	13Cr
8	YOKE NUT	GGG40.3
9	HAND WHEEL	CS

No.	PART	MATERIAL
10	NUT	A194-2H
11	WASHER	CS
12	BOLT	A193-B7
13	NUT	A194-2H
14	WASHER	CS
15	EYE BOLT	A193-B7
16	PIN	CS
17	BOLT	A193-B7
18	NUT	A194-2H

#### Dimension in mm

SIZES	1/2"	3/4"	1"	1.1/4"	1.1/2"	2"	2.1/2"	3"	4"	5"	6"	8"	10"	12"
DN	15	20	25	32	40	50	65	80	100	125	150	200	250	300
L	130	150	160	180	200	230	290	310	350	400	480	600	650	745
H	170	195	200	235	270	275	365	420	465	480	545	680	735	895
D	95	105	115	140	150	165	185	200	220	250	285	340	445	515
N-Ø	14	14	14	18	18	18	18	18	23	27	27	30	32	35

The contents of this literature are for informative purposes only. Arita is not responsible for suitability or compatibility of these products in relation to system requirement. For specific requirements, consult Arita or its distributors. Arita reserves the right to change or modify product design without prior notice.