



UNIMECH GROUP, MALAYSIA



A MEMBER OF UNIMECH GROUP, MALAYSIA

CAST IRON GLOBE VALVE FLANGED END PN16



Features :

Face to Face is according to BS5150/5163

Flange drilled is according to BS4504

Working Pressure : PN 16

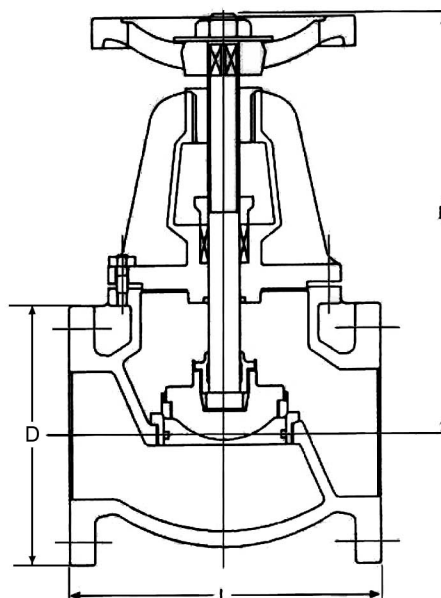
Test Pressure Shell : 24 kgf/cm²Seat : 17.6 kgf/cm²

Technical Data

Material

No.	PART	MATERIAL
1	BODY	CAST IRON (A126)
2	BONNET	CAST IRON (A126)
3	STEM	STAINLESS STEEL (SS410)
4	DISC	CAST IRON (A126)
5	SEAT RING	CAST BRONZE / STAINLESS STEEL (B62)
6	GLAND	DUCTILE IRON (FCD45)
7	PACKING	NOT ASBESTOS
8	HANDWHEEL	CAST IRON (A126)

Dimension in mm

SIZES		L	H	D
DN	in.			
40	1.1/2"	190	260	140
50	2"	203	277	152
65	2.1/2"	216	307	178
80	3"	241	353	190.5
100	4"	292	404	229
125	5"	360	454	254
150	6"	410	533	279
200	8"	495	642	343
250	10"	620	665	406
300	12"	700	755	483