



UNIMECH GROUP, MALAYSIA



A MEMBER OF UNIMECH GROUP, MALAYSIA

## CAST IRON GATE VALVE FLANGED END PN 16 (NON RISING STEM)



### Features :

Face to Face is according to BS5150/5163

Flange drilled is according to BS4504

Working Pressure : PN 16

Test Pressure Shell : 24 kgf/cm<sup>2</sup>

Seat : 17.6 kgf/cm<sup>2</sup>

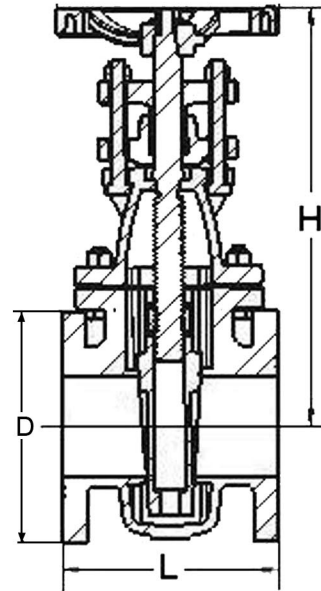

### Technical Data

#### Material

No.	PART	MATERIAL
1	BODY	CAST IRON (A126)
2	BONNET	CAST IRON (A126)
3	STEM	STAINLESS STEEL (SS410)
4	DISC	CAST IRON (A126)
5	SEAT RING	CAST BRONZE / STAINLESS STEEL (B62)
6	GLAND	DUCTILE IRON (FCD450)
7	PACKING	NOT ASBESTOS
8	HANDWHEEL	CAST IRON (A126)

#### Dimension in mm

SIZES		L	H	D
DN	in.			
40	1.1/2"	165	245	150
50	2"	178	252	165
65	2.1/2"	190	270	185
80	3"	203	290	200
100	4"	229	365	220
125	5"	254	420	250
150	6"	267	455	285
200	8"	292	575	340
250	10"	330	686	405
300	12"	365	782	460

The contents of this literature are for informative purposes only. Arita is not responsible for suitability or compatibility of these products in relation to system requirement. For specific requirements, consult Arita or its distributors. Arita reserves the right to change or modify product design without prior notice.