



UNIMECH GROUP, MALAYSIA



A MEMBER OF UNIMECH GROUP, MALAYSIA

CAST IRON GLOBE VALVE FLANGED END JIS 10K

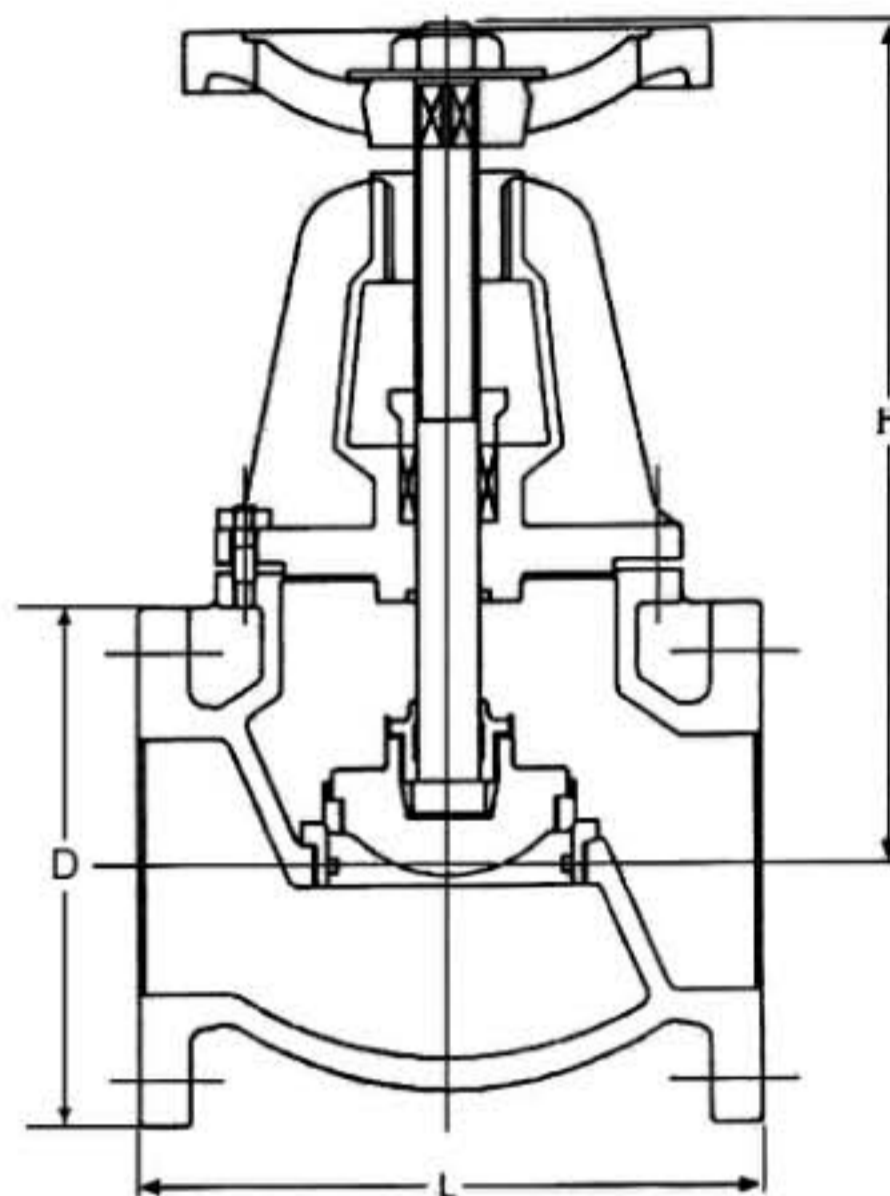

Features :

- Face to face is according to JIS B2002
- Flange drilled is according to JIS B2012
- Working Pressure : 10K
- Test Pressure Shell : 21.1 kgf/cm²
- Seat : 15.0 kgf/cm²

Technical Data

Material

No.	PART	MATERIAL
1	BODY	CAST IRON (FC20)
2	BONNET	CAST IRON (FC20)
3	STEM	STAINLESS STEEL (SS410)
4	DISC	CAST IRON (FC20)
5	SEAT RING	CAST BRONZE / STAINLESS STEEL (B62)
6	GLAND	DUCTILE IRON (FC20)
7	PACKING	NOT ASBESTOS
8	HANDWHEEL	CAST IRON (FC20)

Dimension in mm

SIZES		L	H	D
DN	in.			
40	1.1/2"	190	260	140
50	2"	200	277	155
65	2.1/2"	220	307	175
80	3"	240	353	185
100	4"	290	404	210
125	5"	360	454	250
150	6"	410	533	280
200	8"	500	642	330
250	10"	620	665	400
300	12"	700	755	445